



MIX S.r.l.

MIXING SYSTEMS AND
COMPONENTS FOR PLANTS

www.mixitaly.com

Technische Datenblätter

Absperrorgane



 **ATEX-AUSFÜHRUNGEN VERFÜGBAR**

Drehklappen Kombinationstabelle

SVA

H

Ausführung

N: Standard
A: ATEX II 2/3D Ex h IIIB T100°C Db/Dc X

Klassifizierung
MSR
Unvollständige Maschine

Nenndurchmesser
100 - 150 - 200 - 250
300 - 350 - 400

Welle

A2: Kurze Vierkantwelle
ISO 5211
C2: Kurze Vielkeilwelle
DIN 5482
K2: Lange Vierkantwelle
ISO 5211
L2: Lange Vielkeilwelle
DIN 5482

Dichtung

A: Standard staubdicht bei Raumdruck
B: Dichtung für 0,2 bar im Überdruck oder Unterdruck geeignet (bei Raumtemperatur geprüft)

Ausführung

6: Körper und Klappenteller in Aluminiumguss, niedrige Dichtung
7: Körper in Aluminiumguss und Klappenteller in Edelstahl 1.4301, niedrige Dichtung
8: Körper in Aluminiumguss und Klappenteller aus Edelstahl 1.4301, hohe Dichtung
9: Körper und Klappenteller in Aluminiumguss, hohe Dichtung

MATERIAL DER DICHTUNG UND BETRIEBSTEMPERATUR

VERSION	MATERIAL	FARBE	FORM	STANDARD	ATEX
1	NBR	Weiß	Hoch / Niedrig	-20°C / + 100°C	-20°C / + 100°C
2	NBR, FDA zertifiziert		Hoch	-20°C / + 100°C	
5	HNBR-THERBAN	Schwarz	Hoch / Niedrig	-25°C / + 150°C*	
9	NBR, 1935/2004 zertifiziert**	Weiß	Hoch	-20°C / + 100°C	

* Auf Anfrage, ist für die Version mit langer Welle unter Verwendung einer speziellen Arbeitsanweisung (ILO945), und einer niedrigen VITON-Dichtung eine Betriebstemperatur -25 °C / +230 °C möglich

** Drehklappe komplett mit Konformitätserklärung für den Lebensmittelkontakt gemäß Verordnungen (EG) 1935/2004 & 2023/2006

Abb.01

Abb.01

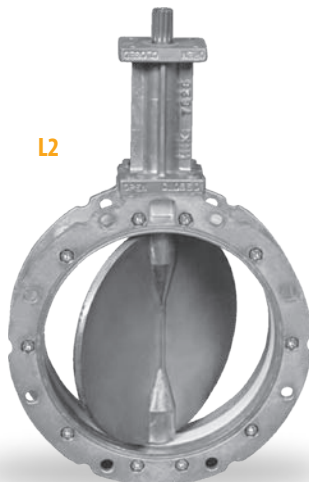
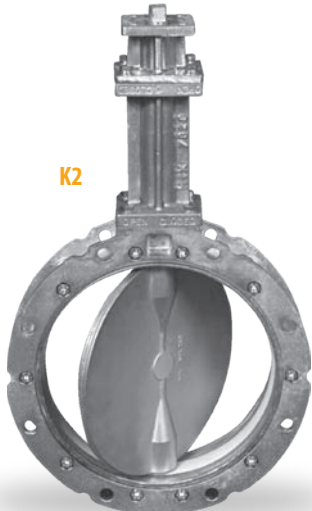
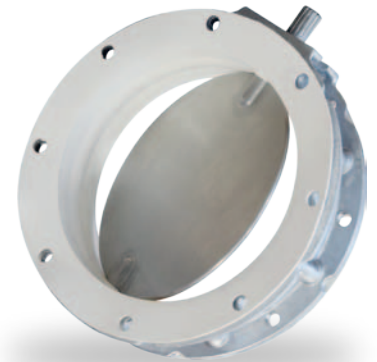
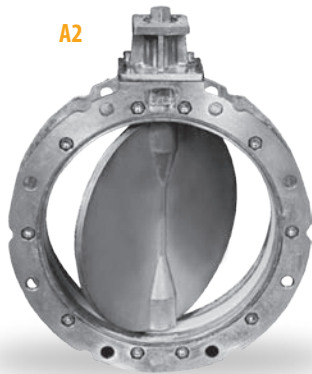

“Niedrige Dichtung”
(im Bereich des Klappentellers)

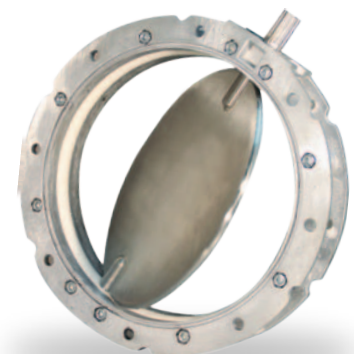

.-SVAH...A2... / .-SVAH...K2...

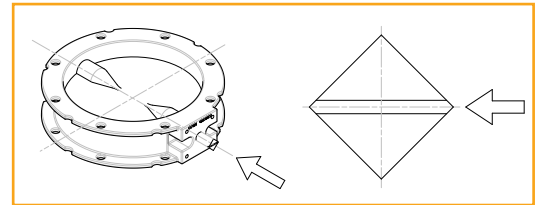
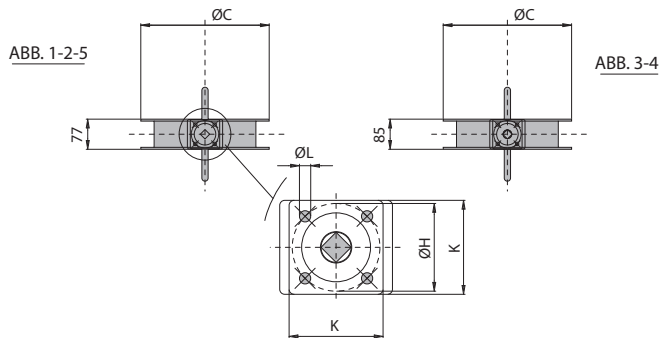

Kurze Vierkantwelle

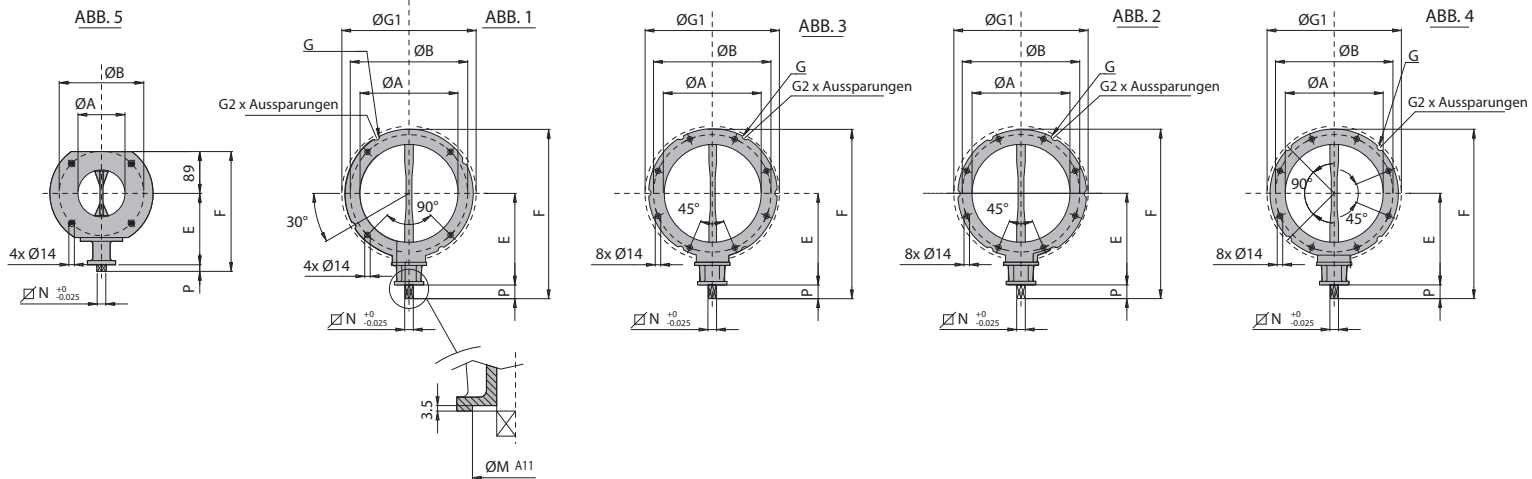

Lange Vierkantwelle

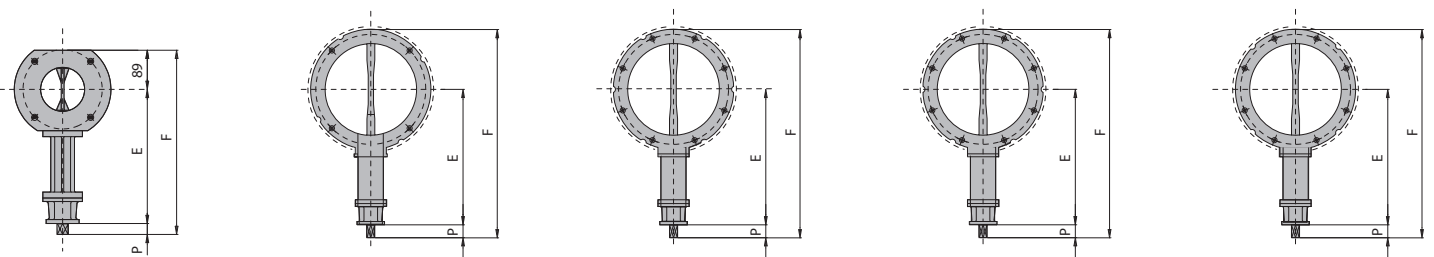

			.-SVAH...2...															A2...		K2...				
TYP	Inch	mm	Abb.	ISO	A	B	C	G	G1	G2	PN	ND	H	K	L	M	N	P	E	F	kg	E	F	kg
.-SVAH100.2...	4"	100	5	F05	100	180	220	/	/	/	10	10	50	60	7	35	14	14	152	255	5	306	409	6,3
.-SVAH150.2...	6"	150	1	F07	150	200	228	9	225	4	6	6	70	75	9	55	17	16	177	307	5,5	331	461	6,8
.-SVAH200.2...	8"	200	1	F07	200	250	278	9	280	4	6	6	70	75	9	55	17	16	202	356	7,5	356	510	8,8
.-SVAH250.2...	10"	250	2	F07	250	300	328	9	335	6	6	6	70	75	9	55	17	16	227	406	8,5	381	560	9,8
.-SVAH300.2...	12"	300	2	F07	300	350	378	11	395	6	6	6	70	75	9	55	17	16	252	456	11,5	406	610	12,8
.-SVAH350.2...	14"	350	3	F10	350	400	440	11	445	6	6	6	102	105	11	70	22	25	289	534	20	489	735	21,8
.-SVAH400.2...	16"	400	4	F10	400	470	530	12,5	515	4	10	10	102	105	11	70	22	25	314	604	23	514	804	24,8

.-SVAH...C2... / .-SVAH...L2...

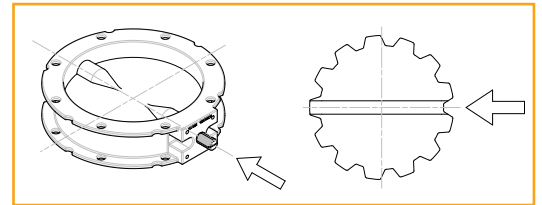
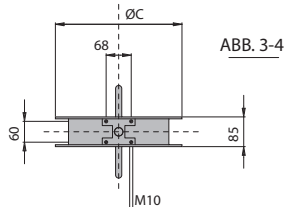
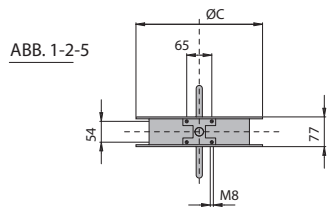

Kurze Vielkeilwelle

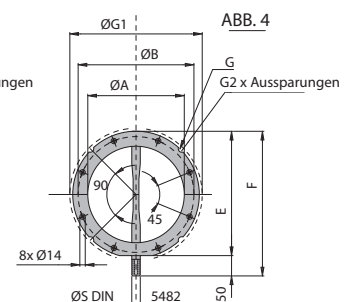
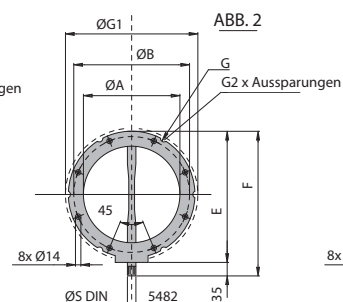
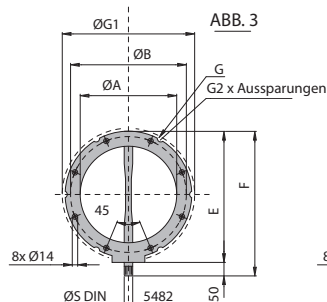
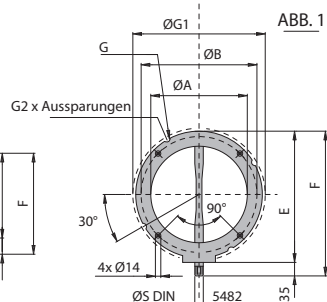
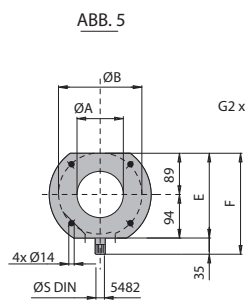

Lange Vielkeilwelle

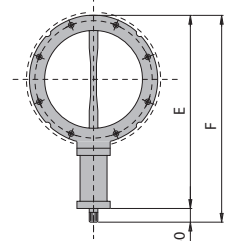
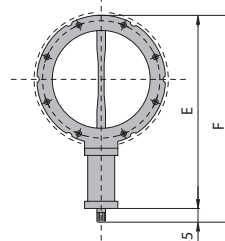
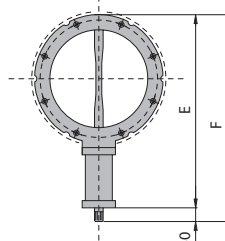
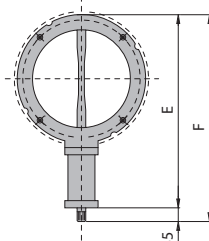
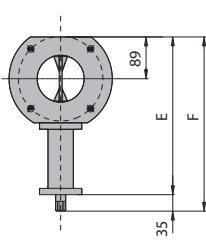

			.-SVAH...2...										C2...			L2...		
TYP	Inch	mm	Abb.	A	B	C	G	G1	G2	PN	ND	S	E	F	kg	E	F	kg
.-SVAH100.2...	4"	100	5	100	180	220	/	/	/	PN10	ND10	22x19	183	218	4,5	337	372	5,8
.-SVAH150.2...	6"	150	1	150	200	228	9	225	4	PN6	ND6	22x19	233	268	5	387	422	6,3
.-SVAH200.2...	8"	200	1	200	250	278	9	280	4	PN6	ND6	22x19	282	317	7	436	471	8,3
.-SVAH250.2...	10"	250	2	250	300	328	9	335	6	PN6	ND6	22x19	332	367	8	486	521	9,3
.-SVAH300.2...	12"	300	2	300	350	378	11	395	6	PN6	ND6	22x19	382	417	11	536	571	12,3
.-SVAH350.2...	14"	350	3	350	400	440	11	445	6	PN6	ND6	28x25	439	489	20	639	689	22,3
.-SVAH400.2...	16"	400	4	400	470	530	12,5	515	4	PN10	ND10	28x25	509	559	23	709	759	25,4

Zubehör Drehklappen

WULSTSTUTZEN FÜR SCHLAUCHANSCHLUSS - SFU



SFU

B

Runder
Flanschanschluss

Neendurchmesser
100 - 150 - 200 - 250
300 - 350 - 400

Werkstoff
2 = Edelstahl 1.4301
8 = Aluminium

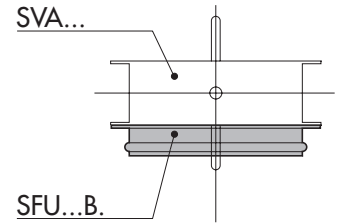
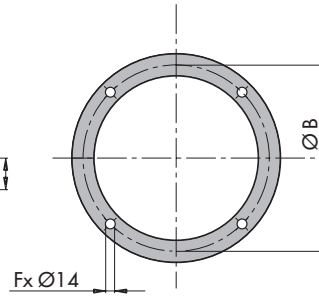
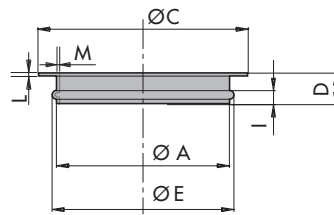

CODE FÜR DIE MONTAGE DURCH MIX	
HAS10	SFU am .-SVAH100÷200
HAS20	SFU am .-SVAH250÷400

Typ	Inch	ØA	ØB	ØC	D	ØE	F	I	L	M	kg
SFU100B2	4"	100	180	220	46	106	4	18	4	2	1,1
SFU150B2	6"	150	200	225	46	156	4	18	8	2	1,6
SFU200B2	8"	200	250	275	46	206	4	18	8	2	2,1
SFU250B2	10"	250	300	325	46	256	8	18	8	2	2,6
SFU300B2	12"	300	350	375	46	306	8	18	8	2	3,0
SFU350B2	14"	350	400	436	50	356	8	18	8	2	4,0
SFU400B2	16"	400	470	525	50	406	8	18	10	2	7,9

Typ	ØA	ØB	ØC	D	ØE	F	I	L	M	kg
SFU100B8	110	180	220	48	125	4	12	2,5	2,5	0,5
SFU150B8	164	200	228	48	178	4	12	2,5	2,5	0,6
SFU200B8	210	250	278	48	223	4	12	2,5	2,5	0,7
SFU250B8	265	300	328	48	275	8	12	2,5	2,5	1,1
SFU300B8	315	350	378	48	328	8	12	2,5	2,5	1,3
SFU350B8	354	400	440	53	365	8	12	3	3	1,9
SFU400B8	404	470	530	53	417	8	12	3	3	2,7

FLANSCH - KFT



KFT

Flansch

Neendurchmesser
100 - 150 - 175 - 200
250 - 300 - 350 - 400

Werkstoff
1 = lackierter Normalstahl (RAL 9006)
2 = Edelstahl 1.4301



* KFT 100



KFT 150 ÷ KFT 400

KFT...A.

Typ	Ø A	Ø B	Ø C	D	kg
* KFT100A1	116	180	220	6	1,29
* KFT100A2	116	180	220	4	0,86
KFT150A.	170	200	228	6	0,85
KFT175A.	195	250	278	8	1,94
KFT200A.	221	250	278	6	1,05
KFT250A.	275	300	328	6	1,18
KFT300A.	325	350	378	6	1,38

KFT...C.

Typ	Ø A	Ø B	Ø C	D	kg
* KFT100C1	103	180	220	6	1,40
* KFT100C2	103	180	220	4	0,93
KFT150C.	155	200	228	6	1,03
KFT200C.	205	250	278	6	1,30
KFT250C.	256	300	328	6	1,56
KFT300C.	305	350	378	6	1,84
KFT350C.	358	400	440	6	2,42
KFT400C.	409	470	530	10	7,01

KFT....

x F	SVA
4	100
4	150
4	200
8	250
8	300
8	350
8	400

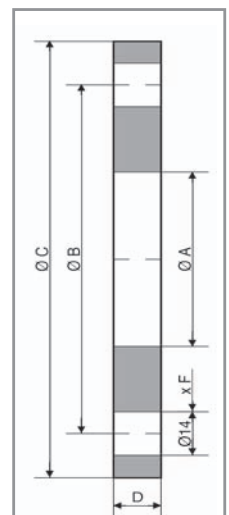

Antriebe Drehklappen

RAB



C

TYPE	A	B	C	D	kg	SVA
RAB22C	65	27	8,5	22 X 18 DIN 5482	1,7	100 - 300
RAB28C	68	30	10,5	28 X 25 DIN 5482	2	350 - 400

Handhebel

Größe
22 - 28

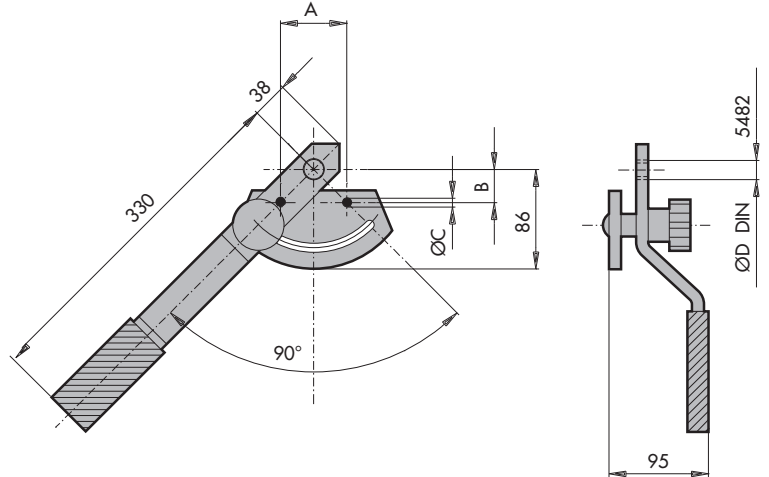

RAM



C



N

Code für die Montage durch MIX	
HAM10	RAM am SVAH100 ÷ 400

Größe
22 - 28

Anzahl Endschalter Mod. FR515

- 2: Endschalter
- 3: Endschalter

Motorantrieb

Nicht als ATEX-Version verfügbar

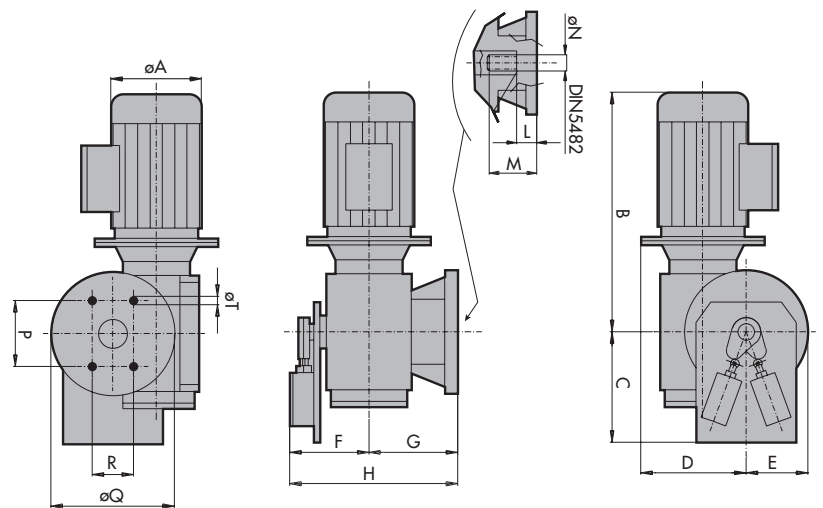
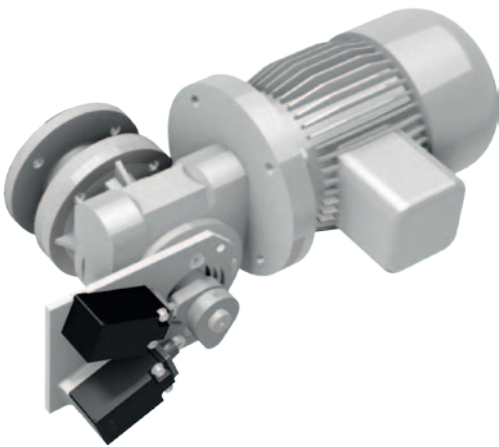

Typ	A	B	C	D	E	F	G	H	L	M	N	P	Q	R	T	kW	Nm*	kg	SVA
RAM22C.N	125	255	115	115	55	95	110	205	16	37	22X19 DIN 5482	65	110	54	8,5	0,20	100	10	100÷300
RAM28C.N	140	300	115	120	70	105	120	225	16	37	28X25 DIN 5482	68	120	60	10,5	0,37	150	18	350÷400

* Der angegebene Wert ist als Anlaufdrehmoment für eine maximale Dauer von 2 Sekunden zu verstehen.

RAP

C



**Pneumatiktrieb
doppeltwirkend**

**Durchmesser des Zylinders
080 - 100 - 125**

Endschalterbox
A: Hoch
B: Niedrig

Ausführung:
P: verpackt
M: zu montieren*
* Siehe S. 9

Ausführung

N: Standard
A: ATEX II 3D Ex h IIIB T100°C Dc X

Anschluss für Welle

S: ISO 5211 Kupplung
X: DIN 5482 Kupplung

KOMBINATIONSTABELLE	
ISO 5211	DIN 5482
.-RAPC080S.	.-RAPC080X.
.-RAPC100S.	.-RAPC100X.
	.-RAPC125XA.

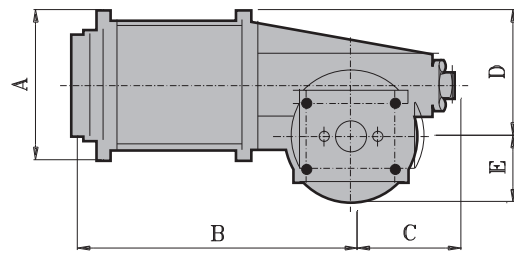
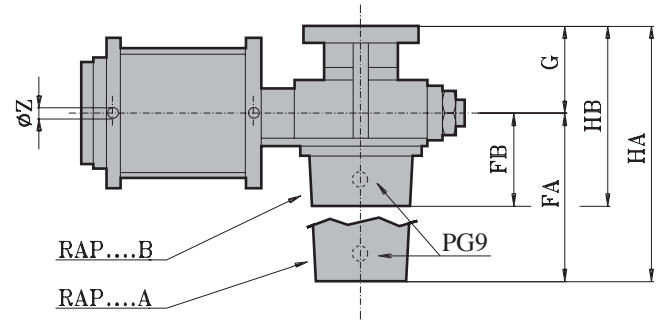
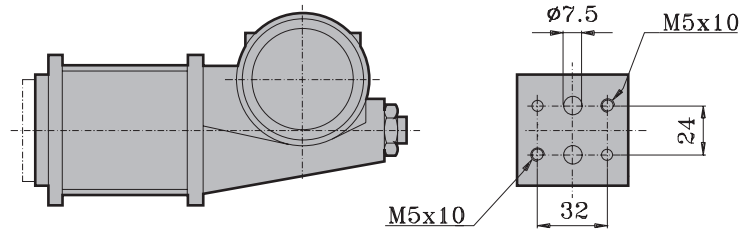
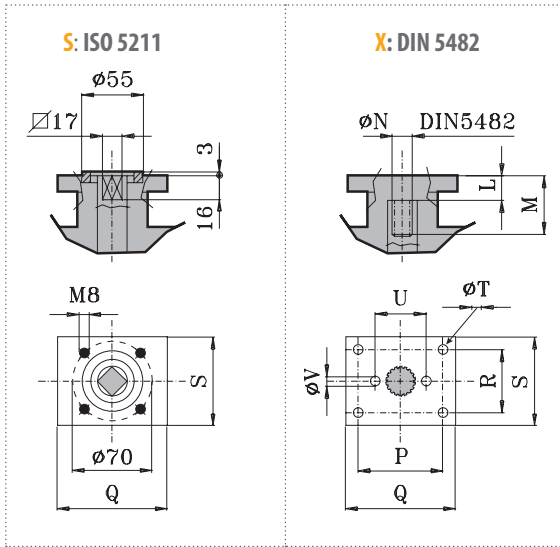

Typ	Luftverbrauch für Bedienung	Bedienzeit @ 6 bar
.-RAPC080	1,8 NI	~ 0,5 s
.-RAPC100	2,8 NI	
.-RAPC125	7,6 NI	

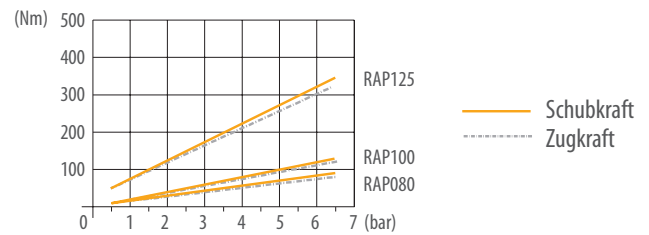

Typ	A	B	C	D	E	FA	FB	G	HA	HB	L	M	N	P	Q	R	S	T	U	V	Z	kg	SVA
.-RAPC080	90	200	100	84	58	150	75	62	212	137	19	37	22X19 DIN 5482	65	90	54	75	9	50	11	1/8"	3,5	100÷300
.-RAPC100	110	210	100	94	58	150	75	62	212	137	19	37	22X19 DIN 5482	65	90	54	75	9	50	11	1/8"	4,5	300
.-RAPC125	137	275	170	124	72	165	90	96,5	262	187	20	52	28X25 DIN 5482	68	106	60	84	10,5	/	/	1/4"	10	350÷400



Zubehör für Antriebe

ENDSCHALTER

Die transparente Endschalterabdeckung erlaubt es, die Position (offen/ open - geschlossen/ closed) des Stellantriebs RAP von außen abzulesen.

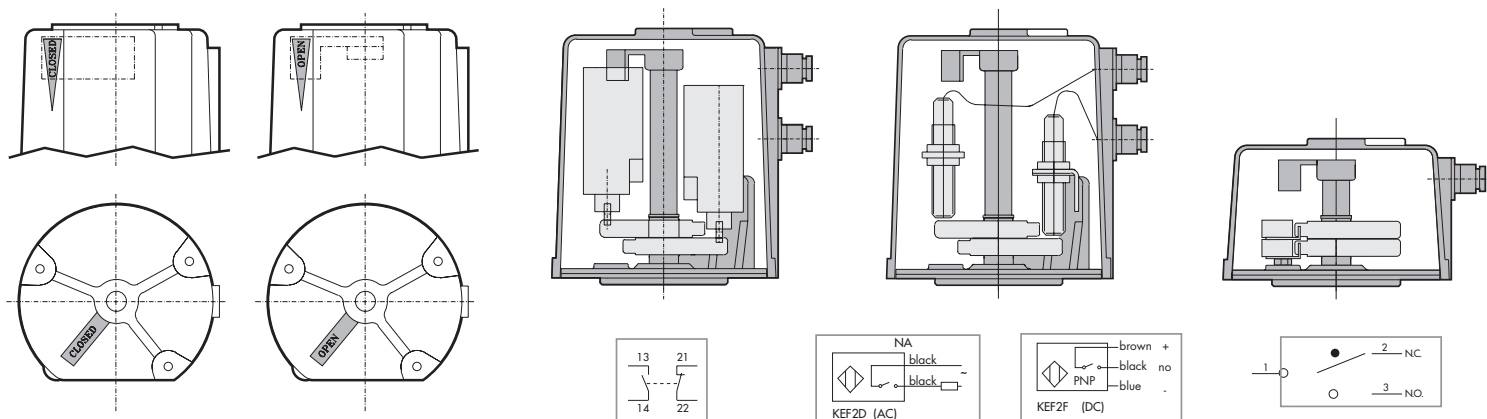

	MECHANIK	INDUKTIV		MECHANISCHE MIKROENDSCHALTER
STANDARD	KEF2C	KEF2D	KEF2F	KEF2E
ATEX	KEH2C	KEH2D	KEH2F	KEH2E*
SPANNUNG	6A - 120V ÷ 3A - 400V AC 2,5A - 24V ÷ 0,25A - 250V DC	20V ÷ 240V AC	5V ÷ 40V DC Typ PNP	6A - 125V ÷ 250V AC 6A - 30V DC
Lieferumfang (inkl. Befestigungsmaterial)				

* nur verfügbar für A-RAP...XB

MAGNETVENTIL



Ausführung
/: Standard (ohne Schalldämpfer)
A: ATEX (mit 2 Schalldämpfern)
II 2G Ex h IIB T5 Gb
II 2D Ex h IIIC T100°C Db

Typ
C = In Linie
D = Namur

Dimensionen
4 = 1/4"
8 = 1/8"

Antrieb
1 = RAPC080
RAPC100
4 = RAPC125

Typ
C = Standard
D = ATEX

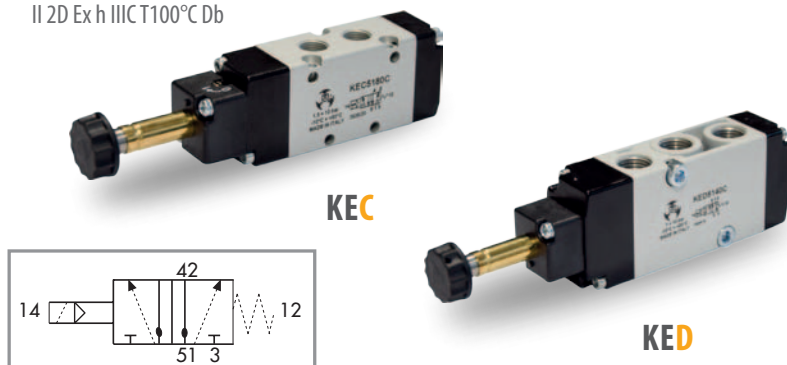
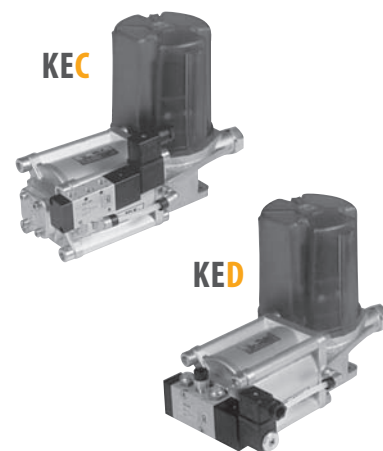

KOMBINATIONSTABELLE		
.-RAP	STANDARD	ATEX
080	KEC 5181C - KED 5141C	A-KEC 5181D - A-KED 5141D
100	KEC 5181C - KED 5141C	A-KEC 5181D - A-KED 5141D
125	KEC 5144C - KED 5144C	A-KEC 5144D - A-KED 5144D

Monostabiles Magnetventil - 5/2-Wege - mit Federrückstellung

SCHALLDÄMPFER

70H3H24

Typ

- 1 = KEC5181 - 1/8"
- 3 = KEC5144 - 1/4"
- KED5141 - 1/4"
- KED5144 - 1/4"



SPULE

KEB

3

Spannung

- 024 = 24 V
- 048 = 48 V
- 115 = 115 V
- 230 = 230 V

Frequenz

- DC: Gleichstrom DC
- AC: Wechselstrom AC 50/60 Hz

KOPPELUNGSTABELLE

KEB 024 DC 3	KEB 024 AC 3
KEB 048 DC 3	KEB 048 AC 3
	KEB 115 AC 3
	KEB 230 AC 3

SPULE ATEX*

CODE	STROMVERORUNGUNG	SCHUTZART	ZERTIFIZIERUNGEN
12A01358	24V DC	IP65	II 3G Ex nA IIC Tx Gc II 3D Ex tc IIIC Tx Dc
12A01352	24V AC		
12A01354	115V AC		



* geeignet für leitende und nicht-leitende Stäube

MONTAGE DURCH MIX

STANDARD	ATEX	CODE FÜR DIE MONTAGE DURCH MIX
HAR10	A-HAR10	.-RAPC080 ÷ 100 an .-SVA 100 ÷ 300
HAR20	A-HAR20	.-RAPC125 an .-SVA 350 ÷ 400
HAE10	A-HAE10	Magnetventil .-KEC in Linie am .-RAPC
HAE20	A-HAE20	Magnetventil .-KED in Namur am .-RAPC
HAF10	A-HAF10	Mechanische Endschalter am .-RAPC
HAF20	A-HAF20	Induktive Endschalter am .-RAPC
HAF30	A-HAF30	Mikroendschalter am .-RAPC

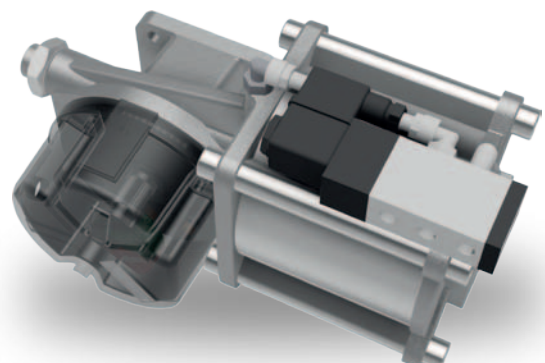
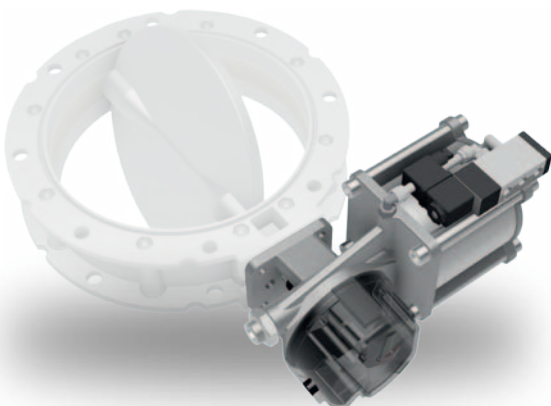

Flachschieber Kombinationstabelle



Antrieb mittels Spindel

Größe \square
 150 - 200 - 250 - 300 - 350
 400 - 500 - 600 - 700 - 800

Werkstoff
 1: lackierter Normalstahl (RAL 9006)
 2: Edelstahl 1.4301

Klassifizierung MSR
 H: unvollständige Maschine
 E: keine Maschine

Ausführung

- N: Standard
- A: ATEX II 2/3D Ex h IIIB T135°C Db/Dc X
(Kennzeichnung für die Version mit Motorantrieb M)
- T: Version für explosionsgefährdete Umgebung geeignet
(für die Version mit freiem Wellenende A und für die Version mit Handrad V)

ANTRIEBSVARIANTEN			
A	Frei	00	Freies Wellenende
V	Handrad	20	SGAE150 ÷ 350
		25	SGAE400 ÷ 800
M	Motorantrieb	04	SGAH150 ÷ 350 = 0,37kW 230/400V 50Hz IP55 CL F
		08	SGAH400 ÷ 800 = 0,75kW 230/400V 50Hz IP55 CL F

Abb.01

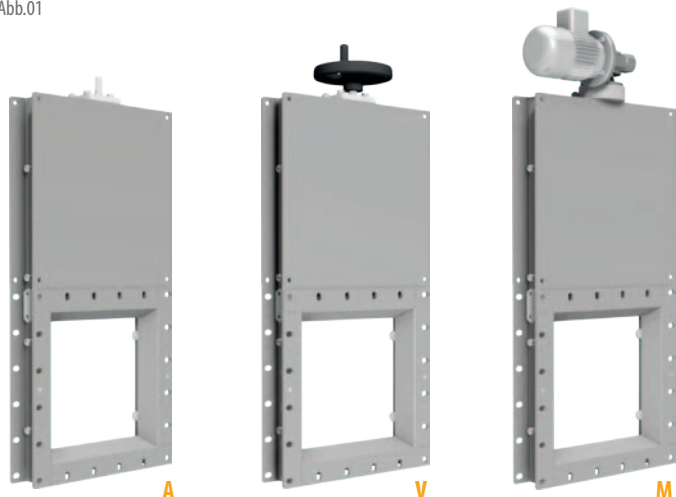

KOMBINATIONSTABELLE		
-.SGAE150A.A00	-.SGAE150A.V20	-.SGAH150A.M04
-.SGAE200A.A00	-.SGAE200A.V20	-.SGAH200A.M04
-.SGAE250A.A00	-.SGAE250A.V20	-.SGAH250A.M04
-.SGAE300A.A00	-.SGAE300A.V20	-.SGAH300A.M04
-.SGAE350A.A00	-.SGAE350A.V20	-.SGAH350A.M04
-.SGAE400A.A00	-.SGAE400A.V25	-.SGAH400A.M08
-.SGAE500A.A00	-.SGAE500A.V25	-.SGAH500A.M08
-.SGAE600A.A00	-.SGAE600A.V25	-.SGAH600A.M08
-.SGAE700A.A00	-.SGAE700A.V25	-.SGAH700A.M08
-.SGAE800A.A00	-.SGAE800A.V25	-.SGAH800A.M08



Ausführung
 N: Standard
 A: ATEX II 2/3D Ex h IIIB T135°C Db/Dc X

Größe \square
 150 - 200 - 250 - 300 - 350
 400 - 500 - 600 - 700 - 800

Werkstoff
 1: lackierter Normalstahl
 (RAL 9006)
 2: Edelstahl 1.4301

Größe der Zylinder
 063: ϕ 63
 080: ϕ 80
 100: ϕ 100
 125: ϕ 125

Antrieb mittels
 Pneumatikzylinder

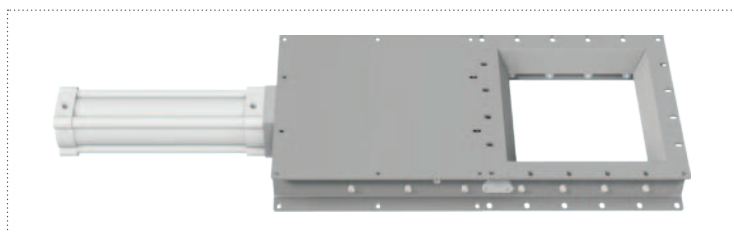

KOMBINATIONSTABELLE			
Kleine Ausführung		Große Ausführung	
-.SGBH150A.063	/	-.SGBH400A.100	-.SGBH400A.125
-.SGBH200A.063	/	-.SGBH500A.100	-.SGBH500A.125
-.SGBH250A.063	-.SGBH250A.080	-.SGBH600A.100	-.SGBH600A.125
-.SGBH300A.063	-.SGBH300A.080	-.SGBH700A.100	-.SGBH700A.125
-.SGBH350A.063	-.SGBH350A.080	-.SGBH800A.100	-.SGBH800A.125

.-SGA...A.A.. / .-SGA...A.V.. / .-SGA...A.M..

Freies Wellenende

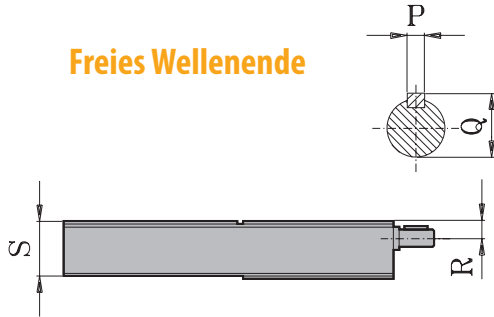

Handrad

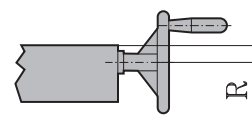

Motorantrieb



Abb.01



Abb.02

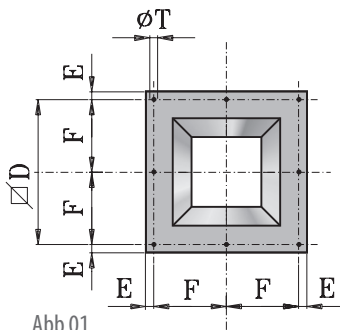
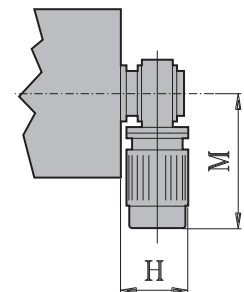
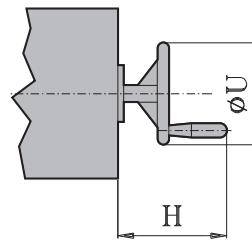
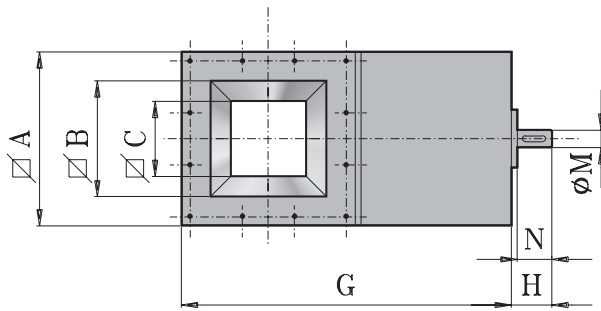
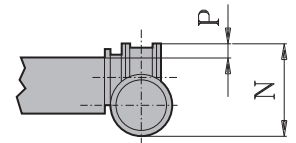

Abb.03

		.-SGA....A.										A..					V..				M..							
Typ	Abb.	A	B	C	D	E	F	G	S	T	H	M	N	P	Q	R	kg	H	R	U	kg	H	M	N	P	kW	*	kg
.-SGA.150A....	1	261	175	120	230	15,5	115	540	93	12,5	56	19	41	6	21,5	30	16	150	30	200	18,8	180	300	200	30	0,37	19	24
.-SGA.200A....	2	311	225	170	280	15,5	93,3	640	93	12,5	56	19	41	6	21,5	30	19	150	30	200	22,5	180	300	200	30	0,37	26	27
.-SGA.250A....	2	361	275	220	330	15,5	110	740	93	12,5	56	19	41	6	21,5	30	25,5	150	30	200	27,5	180	300	200	30	0,37	32	32
.-SGA.300A....	2	431	325	270	385	23	128,3	860	93	12,5	56	19	41	6	21,5	30	32,5	150	30	200	35	180	300	200	30	0,37	39	39
.-SGA.350A....	3	481	375	320	445	18	89	960	93	12,5	56	19	41	6	21,5	30	38,5	150	30	200	42	180	300	200	30	0,37	45	52
.-SGA.400A....	3	533	425	350	500	16,5	100	1090	133	12,5	85	24	41	8	27	45	62,5	190	45	250	69,5	220	340	225	30	0,75	43	96
.-SGA.500A....	3	653	525	450	600	26,5	120	1300	133	15	85	24	41	8	27	45	85	190	45	250	92	220	340	225	30	0,75	54	128
.-SGA.600A....	3	753	625	550	700	26,5	140	1500	133	15	85	24	41	8	27	45	117	190	45	250	125	220	340	225	30	0,75	65	143
.-SGA.700A....	3	895	725	650	825	35	165	1720	133	15	85	24	41	8	27	45	147	190	45	250	150	220	340	225	30	0,75	75	173
.-SGA.800A....	3	995	825	750	925	35	185	1920	133	15	85	24	41	8	27	45	192	190	45	250	195	220	340	225	30	0,75	86	218

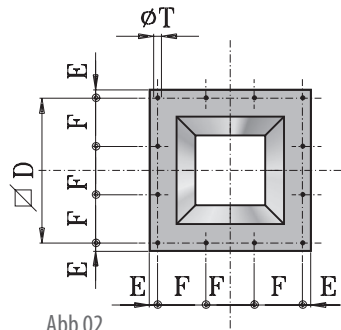
* Zeit in Sekunden, für eine komplette Öffnungs- bzw. Schließbewegung

.-SGB...A....

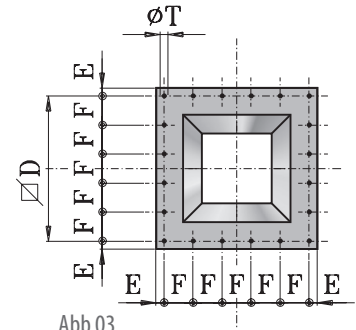
Pneumatikantrieb

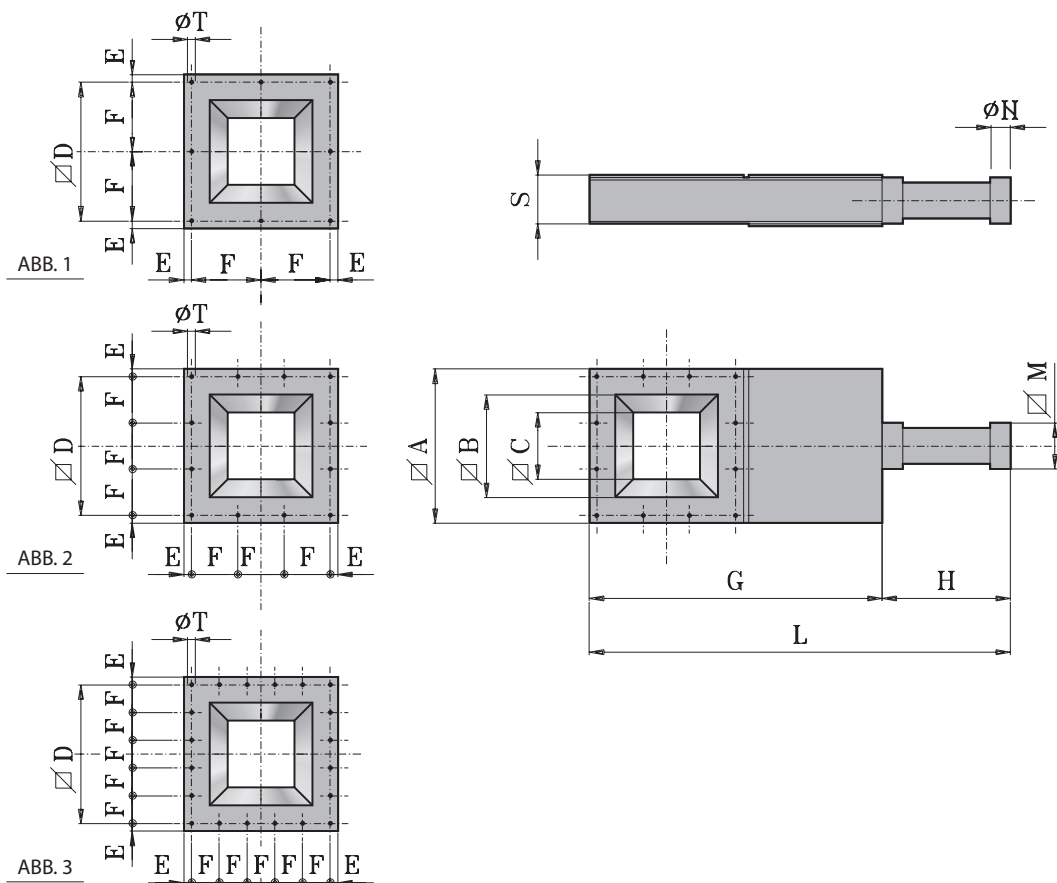

Typ	Abb.	A	B	C	D	E	F	G	H	L	M	**	N	***	S	T	kg
.-SGBH150A.063	1	261	175	120	230	15,5	115	540	275	815	75	\varnothing 63X150	3/8"	2,8	93	12,5	18
.-SGBH200A.063	2	311	225	170	280	15,5	93,3	640	325	965	75	\varnothing 63X200	3/8"	3,7	93	12,5	21,5
.-SGBH250A.063	2	361	275	220	330	15,5	110	740	375	1115	75	\varnothing 63X250	3/8"	4,7	93	12,5	26,5
.-SGBH250A.080	2	361	275	220	330	15,5	110	740	412	1152	95	\varnothing 80X250	3/8"	7,5	93	12,5	28,5
.-SGBH300A.063	2	431	325	270	385	23	128,3	860	425	1285	75	\varnothing 63X300	3/8"	5,6	93	12,5	34,5
.-SGBH300A.080	2	431	325	270	385	23	128,3	860	462	1322	95	\varnothing 80X300	3/8"	9	93	12,5	38
.-SGBH350A.063	3	481	375	320	445	18	89	960	475	1435	75	\varnothing 63X350	3/8"	6,5	93	12,5	42
.-SGBH350A.080	3	481	375	320	445	18	89	960	512	1472	95	\varnothing 80X350	3/8"	10,3	93	12,5	44
.-SGBH400A.100	3	533	425	350	500	16,5	100	1090	545	1635	120	\varnothing 100X400	1/2"	18,8	133	12,5	70
.-SGBH400A.125	3	533	425	350	500	16,5	100	1090	595	1685	150	\varnothing 125X400	1/2"	29,4	133	12,5	76
.-SGBH500A.100	3	653	525	450	600	26,5	120	1300	645	1945	120	\varnothing 100X500	1/2"	23,6	133	15	90
.-SGBH500A.125	3	653	525	450	600	26,5	120	1300	695	1995	150	\varnothing 125X500	1/2"	36,8	133	15	97
.-SGBH600A.100	3	753	625	550	700	26,5	140	1500	745	2245	120	\varnothing 100X600	1/2"	28,3	133	15	122
.-SGBH600A.125	3	753	625	550	700	26,5	140	1500	795	2295	150	\varnothing 125X600	1/2"	44,2	133	15	128
.-SGBH700A.100	3	895	725	650	825	35	165	1720	845	2565	120	\varnothing 100X700	1/2"	33	133	15	158
.-SGBH700A.125	3	895	725	650	825	35	165	1720	895	2615	150	\varnothing 125X700	1/2"	51,5	133	15	169
.-SGBH800A.100	3	995	825	750	925	35	185	1920	945	2865	120	\varnothing 100X800	1/2"	37,7	133	15	204
.-SGBH800A.125	3	995	825	750	925	35	185	1920	995	2915	150	\varnothing 125X800	1/2"	58,9	133	15	216

*** Durchmesser und Länge des Pneumatikzylinders ISO 15552 bis Größe 350 montiert - ab Größe 400 nicht montiert.

*** Luftverbrauch (NI) bei 6 bar für jede Betätigung.

Zubehör

KEC 51 2

Ausführung
 /: Standard (ohne Schalldämpfer)
 A: ATEX (ohne Schalldämpfer)
 II 2G Ex h IIB T5 Gb
 II 2D Ex h IIIC T100°C Db

Dimensionen
 8 = 1/8"
 4 = 1/4"

Typ
 C = Standard
 D = ATEX

Monostabiles Magnetventil - 5/2-Wege - mit Federrückstellung



KOMBINATIONSTABELLE		
Ø ZYLINDER	STANDARD	ATEX
Ø 63	KEC5182C	A-KEC5182D
Ø 80	KEC5182C	A-KEC5182D
Ø 100	KEC5142C	A-KEC5142D
Ø 125	KEC5142C	A-KEC5142D

SCHALLDÄMPFER

70H3H24

STANDARD
 1 = KEC5182C - 1/8"
 3 = KEC5142C - 1/4"

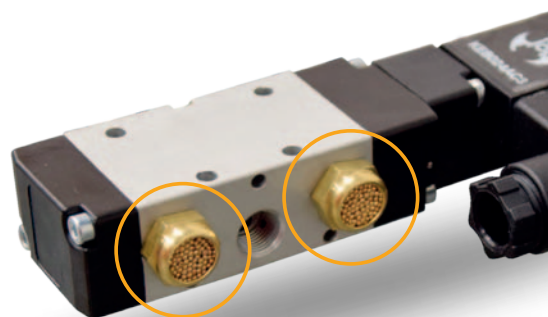

SPULE

KEB 3

SPULE

Spannung
 024 = 24 V
 048 = 48 V
 115 = 115 V
 230 = 230 V

Frequenz
 DC: Gleichstrom DC
 AC: Wechselstrom AC 50/60 Hz

KOPPELUNGSTABELLE	
KEB 024 DC 3	KEB 024 AC 3
KEB 048 DC 3	KEB 048 AC 3
	KEB 115 AC 3
	KEB 230 AC 3

SPULE ATEX*

CODE	STROMVERORUNGUNG	SCHUTZART	ZERTIFIZIERUNGEN
12A01358	24V DC	IP65	II 3G Ex nA IIC Tx Gc II 3D Ex tc IIIC Tx Dc
12A01352	24V AC		
12A01354	115V AC		



* geeignet für leitende und nicht-leitende Stäube



Zubehör

ENDSCHALTER STD IP67



Dimensionen

R1 (magnetisch) = SGB 150÷800 (20V÷220V AC / 20V÷220V DC)

P (induktiv) = SGA 150 (20V÷220V A C) NO

Q (induktiv) = SGA 200÷800 (20V-220V AC) NO

S (induktiv) = SGA 150 (10V÷30V DC) PNP-NO

T (induktiv) = SGA 200÷800 (10V÷30V DC) PNP-NO

MAGNETISCH

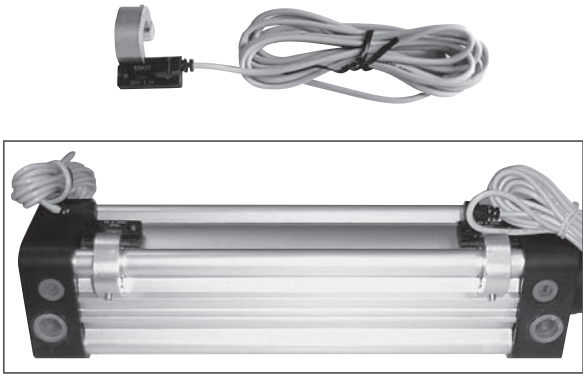

ENDSCHALTER ATEX IP67



Dimensionen

R (magnetisch) = A-SGB 150÷800 (10V÷110V AC / DC) II 3G Ex nC IICT4 Gc / II 3D Ex tc IIIC 110°C Dc

S (induktiv) = A-SGA / A-SGB 150 (20V DC) PNP-NO II 3G Ex nAc IICT6 X / II 3D Ex tc IIIC T80°C X

T (induktiv) = A-SGA / A-SGB 200÷800 (24V DC) PNP-NO II 3G Ex nAc IICT6 X / II 3D Ex tc IIIC T80°C X

INDUKTIV

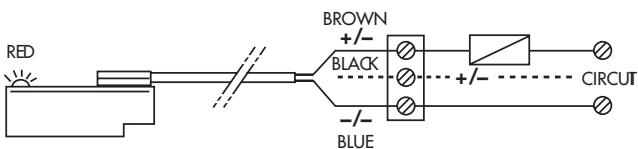
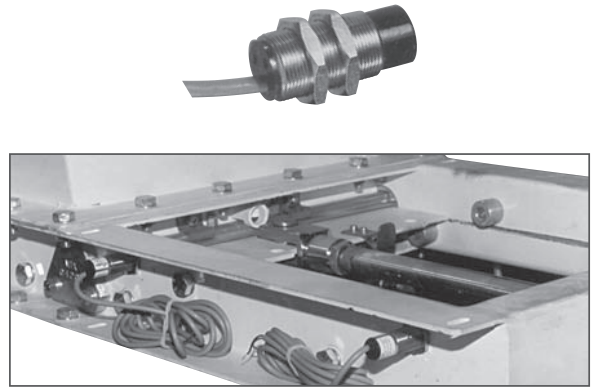

R1 - R

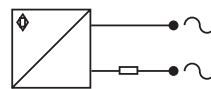

P - Q

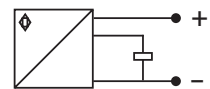

S - T

DICHTUNG SGA - SGB

Die MIX Dichtung besteht aus zwei selbst-zentrierenden Aluminiumflanschen, die zwei geformte Profilverteile aus rostfreiem Edelstahl zusammenhalten. In diesen befinden sich zwei Packungen mit quadratischem Querschnitt, die auch noch einstellbar sind, wenn die Klappe bereits montiert ist. Ab NW 250 lässt sich die Schieberblechabdichtung durch Schrauben nachstellen.

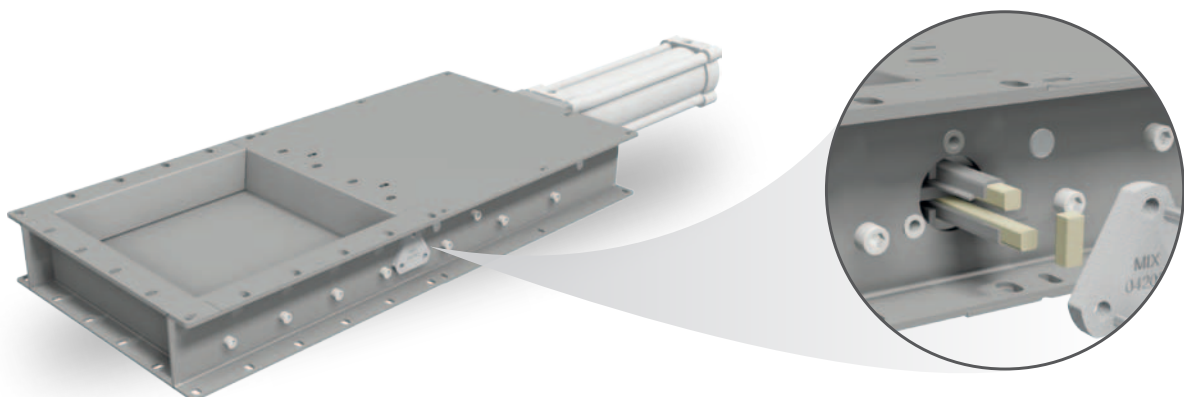

Quetschventile Kombinationstabelle

SMA



A

1

Nenn Durchmesser
080 = 80 mm
100 = 100 mm

Werkstoff der Dichtung
 abriebfester Gummi

Werkstoff
 Körper und Flansch in Aluminiumguss

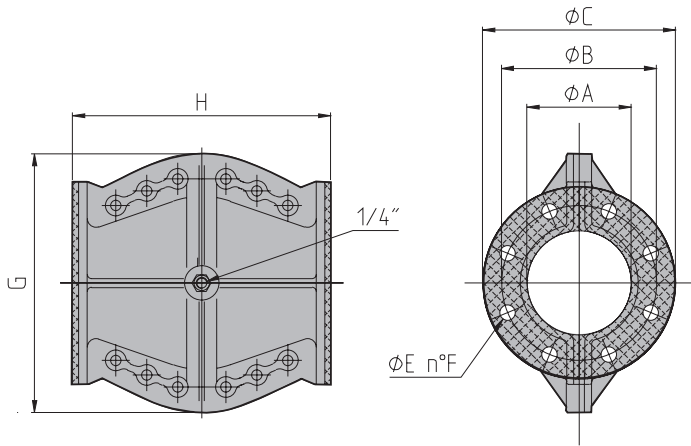

TYPE	A	B	C	E	F	G	H	kg
SMA 080	80	160	200	18	4	254	252	5,8
SMA 100	100	180	220	18	8	302	300	8,6

TECHNISCHE BESCHREIBUNG

Leitungs-/Betriebsdruck: max. 3 bar
Steuerluftdruck: 2 bar höher als der Betriebsdruck
Temperatur: min. -10°C / max. +80°C

MAGNETVENTILE

KEC

51

8

7

C

Monostabiles Magnetventil - 5/2-Wege - mit Federrückstellung

Dimensionen
8 = 1/8"

Standard



CODE FÜR DIE MONTAGE DURCH MIX

HSE10 KEC am SMA

SCHALLDÄMPFER

70H3H24

1

Typ
1 = KEC5181 - 1/8"

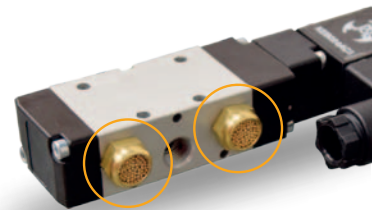

SPULE

KEB



3

SPULE

Spannung
024 = 24 V
048 = 48 V
115 = 115 V
230 = 230 V

Frequenz
DC: Gleichstrom DC
AC: Wechselstrom AC 50/60 Hz



KOPPELUNGSTABELLE

KEB 024 DC 3	KEB 024 AC 3
KEB 048 DC 3	KEB 048 AC 3
	KEB 115 AC 3
	KEB 230 AC 3

Zubehör

GEGENFLANSCH FÜR SMA

Dieser Flansch wird an das Füllrohr des Silos geschweißt, um das Quetschventil daran zu verschrauben.

KFT

Runder Flansch

Ø

Neendurchmesser
080 = 80 mm
100 = 100 mm

D

D = UNI PN10

W

Werkstoff
1 = lackierter Normalstahl (RAL 9006)
2 = Edelstahl 1.4301

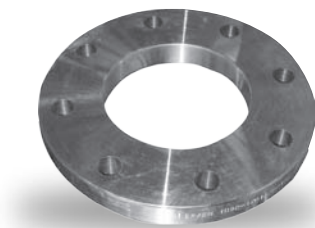

DRUCKWÄCHTER

Er dient der Kontrolle des Luftstroms der Versorgungsluft vom Steuerelektroventil zum Quetschventil. Der Druckwächter kontrolliert, dass der Druck der Druckluft immer über den eingestellten Mindestwerten von 4bar liegt.

SSP

Druckwächter

2

Kontakttyp
NC/NO

4

Dimensionen
Anschluss 1/4"

A

Spannung
24 - 230V AC

1

Ausstattung
Standard mit
Kabel

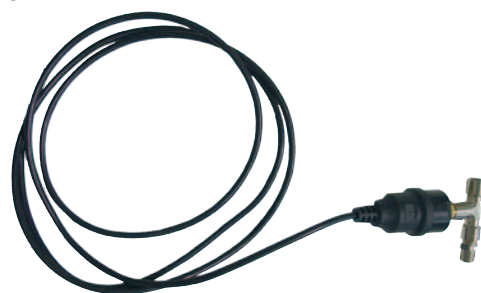

TECHNISCHE DATEN

Schutzart	Betriebs-temperatur	Spannung	Maximal anwendbarer Druck	Eichdruck	Strom des NC Kontaktes (resistive Last / induktive Last)	Strom des NO Kontaktes (resistive Last / induktive Last)
IP56	-20°C +70°C	Max 250V AC	10bar	4bar	15 A / 1,5 A	9 A / 0,9 A

DRUCKLUFTWARTUNGSEINHEIT

Die Einheit wird komplett mit Druckminderer, Druckmesser und Entfeuchtungsfiler geliefert und erlaubt den Druck der Anlage auf den korrekten Betriebsdruck des Quetschventils anzupassen und hilft damit den Luftverbrauch zu verringern und die Lebensdauer der Dichtung des Quetschventils zu erhöhen.

SKR

Druckminderer

4

Abmessungen
Anschluss
4 = 1/4"

E

Betriebsdruck
0,5 ÷ 8,5 bar

5

Komponenten
Druckminderer,
Druckmesser,
Entfeuchtungsfiler

B

Verwendete Armaturen
Mit Armaturen für Ventil SMA



TECHNISCHE DATEN

Abfluss des Kondenswassers	Gewicht	Kupplung	Abscheidung des Kondenswassers	Betriebstemperatur	Gefäßkapazität
Halbautomatisch	0,12 Kg	G1/4"	> 90%	Max: +50°C	12 cm ³

Untersiloklappen Kombinationstabelle

SV

Verbindung

Q: Viereckiger Anschluss

T: Runder Anschluss

Abb.01

Größe

250 - 300

C2

**Kurze Vielkeilwelle
DIN 5482**

Abb.02

C

1

**Werkstoff des Körpers
und des Klappentellers**

1: lackierter Normalstahl
(RAL 9006)

1

Werkstoff der Dichtung

1: NBR (-15 ÷ +100 °C)

**Staubdicht bei
Raumdruck**

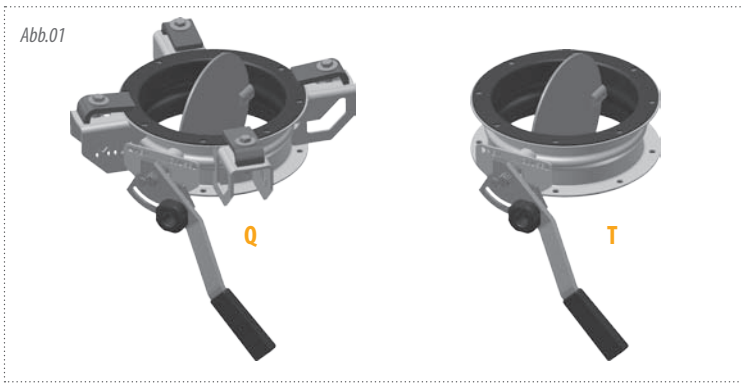

SVQ

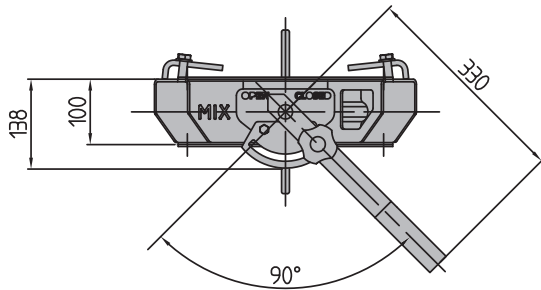

SVT

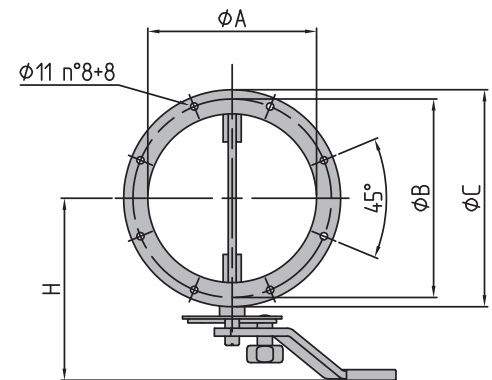
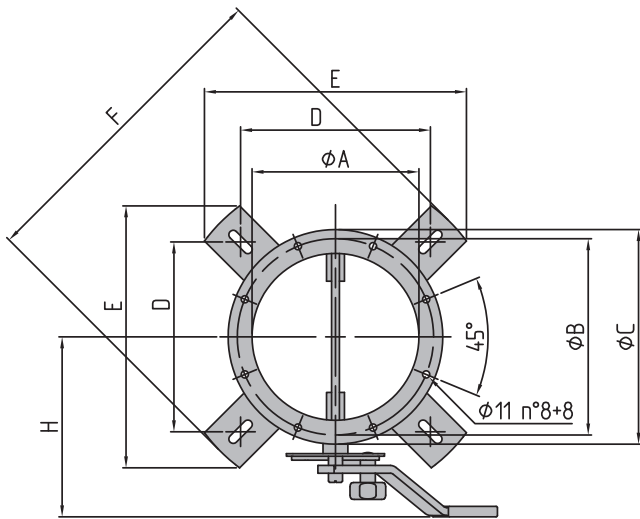
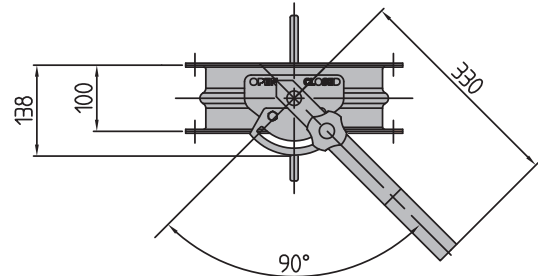

Typ	A	B	C	D	E	F	H	kg
SVQ250	250	300	328	290	400	500	275	14,2
SVQ300	300	350	378	350	490	620	300	16,7

Typ	A	B	C	D	E	F	H	kg
SVT250	250	300	328	-	-	-	275	9,4
SVT300	300	350	378	-	-	-	300	11,2

INTERCEPTION SYSTEMS AND COMPONENTS FOR PLANTS

QUALITY
SERVICE
TECHNOLOGY
INNOVATION

www.mixitaly.com



MIX S.r.l. - 41032 CAVEZZO (MO) - Via Volturmo, 119/A - ITALY
Tel. +39 0535.46577 - Fax +39 0535.46580 - info@mixitaly.com