



MIXER MIX® TYPE MXC



**HOMOGENIZER
 COMPLETE WITH KNIVES**
 - Efficient Lump-breaking action
 - Improved mixing

2

MIXER

- Optimal mixing
- Minimum residue after discharge
- Accurate finishing

1



COMPACT DRIVE

- Optimized performance
- Low maintenance
- Reduced encumbrance

3

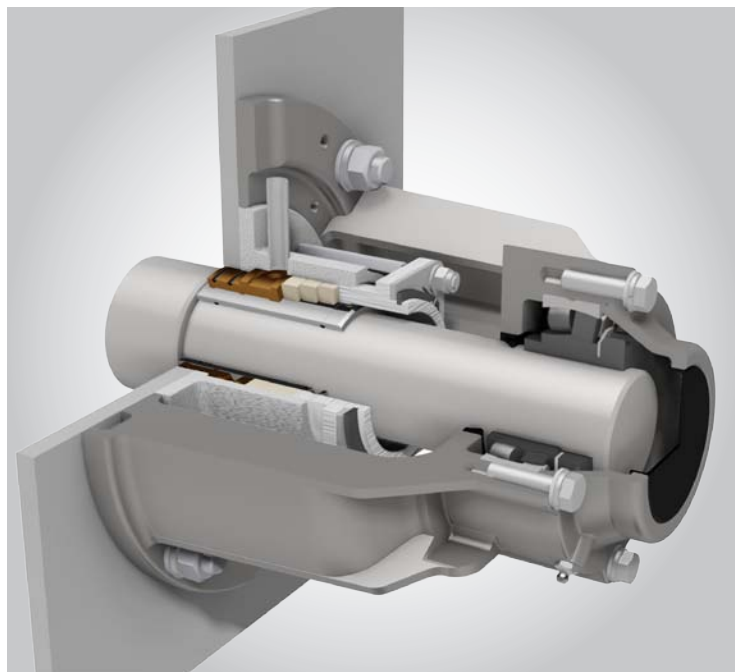

SECTION OF SHAFT AND SEAL

- Perfect sealing
- Predisposition for fluid blowing
- Easy maintenance

4

INSPECTION HATCH

Excellent sealing -
Total safety -
Easy inspections -

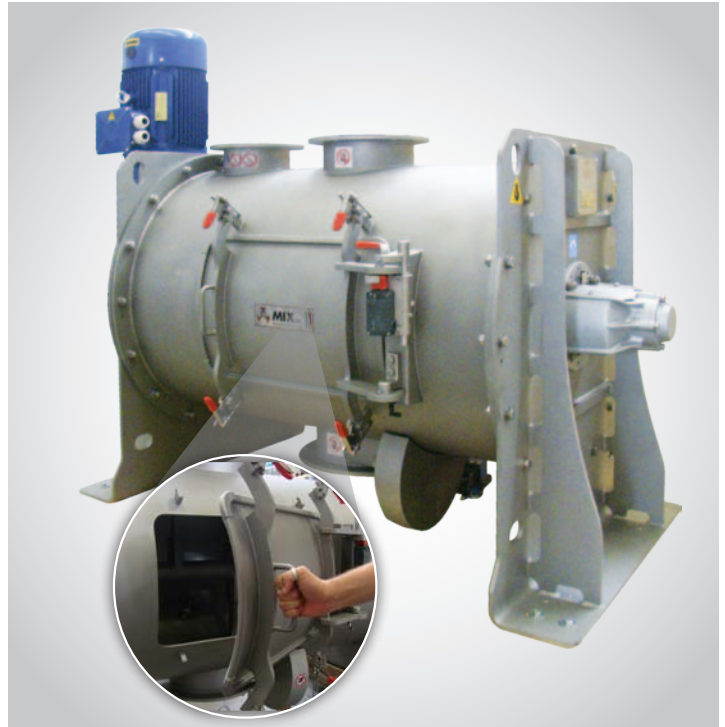
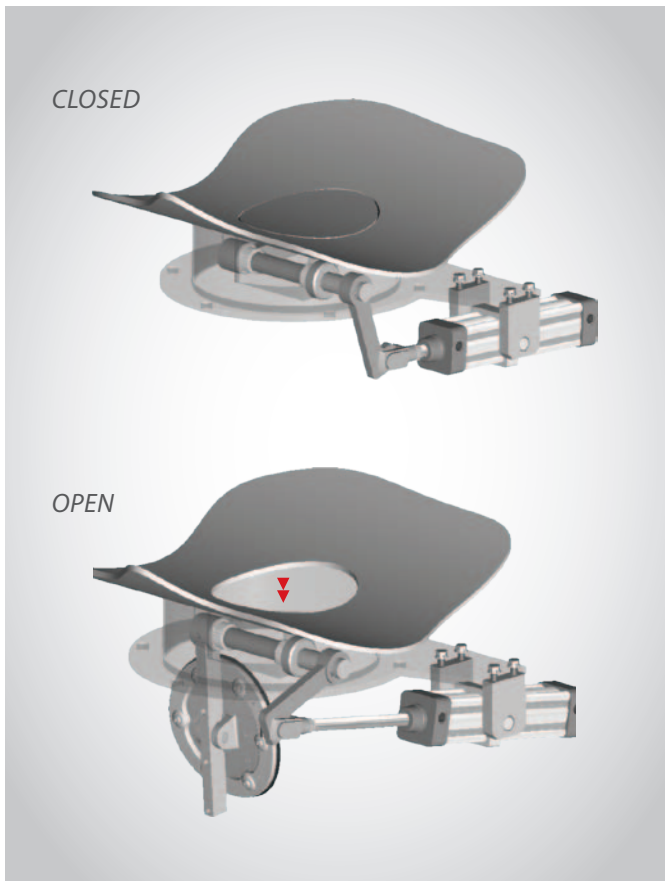

ROUND DISCHARGE DOOR WITH CYLINDER

- Self-cleaning system with lip seal
- Perfect reconstruction of the circularity of the mixing chamber

BOMB DISCHARGE DOOR WITH CYLINDER

- Reduced discharging time
- Minimum residue after discharge
- Maximum productivity

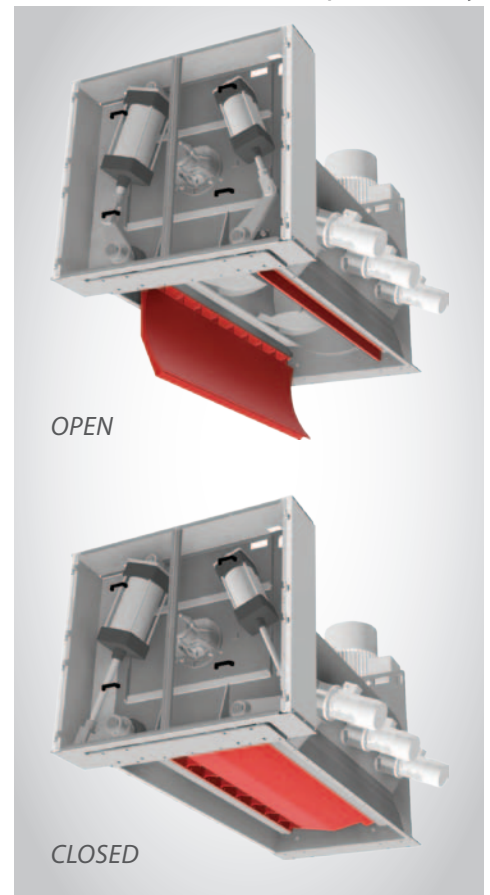
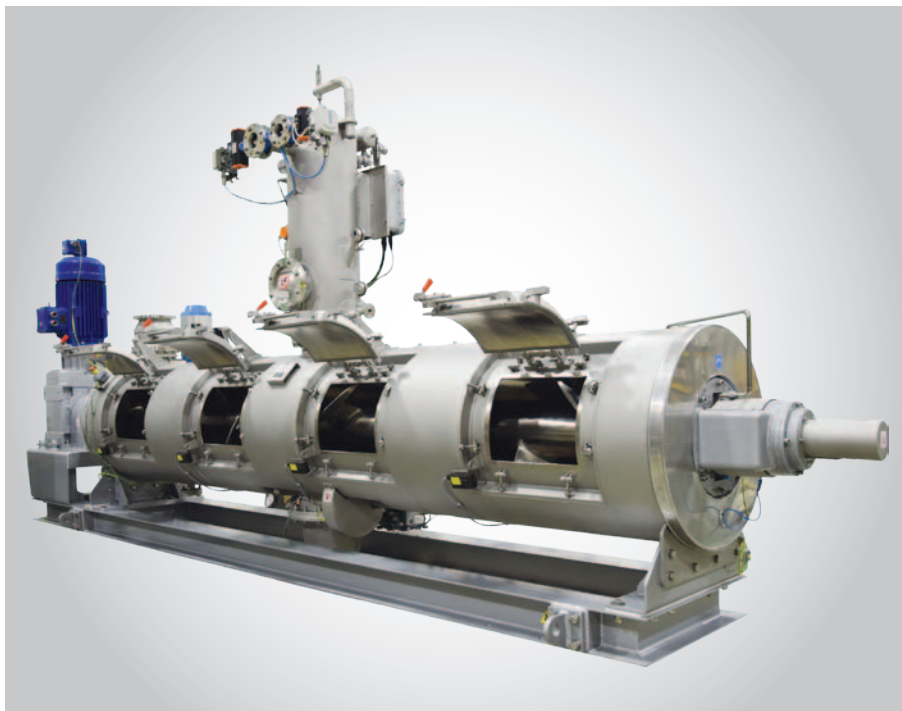

ATEX AND PED CERTIFICATION

- Wide range of products certified ATEX and PED
- As an example is shown a vacuum dryer with:**
- Heat exchanger built directly on the mixing chamber
- Four hatches to inspect chamber inside

MIX® S.r.l. - 41032 CAVEZZO (MO) - Via Volturmo, 119/A - ITALY
Tel. +39.0535.46577 - Fax +39.0535.46580 - www.mixitaly.com - info@mixitaly.com

LONGER LIFE • EASY MAINTENANCE • COMPETITIVE PRICE • QUALITY • SERVICE